



BONOS[®] COAXIAL CHIMNEYS INSTALLATION INSTRUCTIONS

The way of installation and composition of materials (valid for all kinds of tin chimneys and ventilation) shown in the following text, are protected by Patent. Any unauthorized, partial or complete application (installation in the way shown here) will be considered intellectual property theft, and will be, as such, legally sanctioned.

INTER BONOS[®] Ltd.

Production, construction services and trade, Registration number: 1850741
Sv.Helene 3, 10430 Samobor, Tel: (1) 3361 729, 3370 643, Fax: 3370 644,
Mobile phone: 091 722 8262, E-mail: info@interbonos.hr
www.interbonos.hr

INSTALLATION INSTRUCTIONS

Metal chimney, which is used for the bringing out of the gas as a product of burning in the thermal units for burning placed in the building, as shown in figures 1 and 2 consists of a body of two coaxial metal tubes. Through the inner, flue tube 1, gas as a product of burning in the thermal units for burning of solid or gaseous fuels placed in the rooms of a building is brought out, and through the ring-like space between the inner tube 1 and the outer, air outlet tube 2, the air for burning of fuels in the firebox of these thermal units is brought in. Both tubes consist of sections that are connected by overlapping conjunctions and joints. In some sections, the inner tube 1 and the outer tube 2 are connected with small pieces that hold them together and keep their reciprocal central position in relation with their mutual longitudinal axis of symmetry. Due to complicated thermodynamic and climatic conditions to which the chimney is exposed during its usage, both tubes have to be made of flame-retardant and corrosion-resistant metal, such as stainless steel.

The body of the metal chimney, i.e. metal canal is placed in the openings 3 that are on the mutual vertical axis and brought out on the slabs between floors 4. The openings can be round or polygonal. The sides of the opening can be vertical or conical so that the opening is funnel-shaped. The openings are made during the building of slabs between the floors in new buildings in which the installing of metal chimney, i.e. metal canal is planned in the project, or later in the already existing buildings.

The connection of the body of the chimney, i.e. body of the canal, with the slabs between the floors is made using a two-part ring-like clamp (support) 5. The clamp 5 is made of two semicircular metal semi rings with rectangular cut that at both ends finish with vertical parts that have holes for bolts 6 with the help of which the clamp 5 is screwed to the body of the chimney, i.e. the canal, using nuts 7. On every semi ring of the clamp 5 one or more horizontal metal adjustable legs 8 are welded, and these legs can be made of metal profile with circular or rectangular cut. The clamp 5 is tightened to the body of the chimney, i.e. the canal on the same level as the upper surface of the slabs between the floors 4 so that its extensions 8 lie on the slabs 4. When the chimney, i.e. the canal is put next to the partition wall 9, the semi ring of the clamp 5 which is put next to the partition wall 9 has extensions 8 with circular cuts which are inserted into the holes in the partition wall 9, as shown on the lower slab 4. On the free side, the semi ring of the clamp 5 has extensions 8 with rectangular cut which are screwed to the upper surface of the slab with bolts 10, as shown on the upper and lower slab 4.

1/2

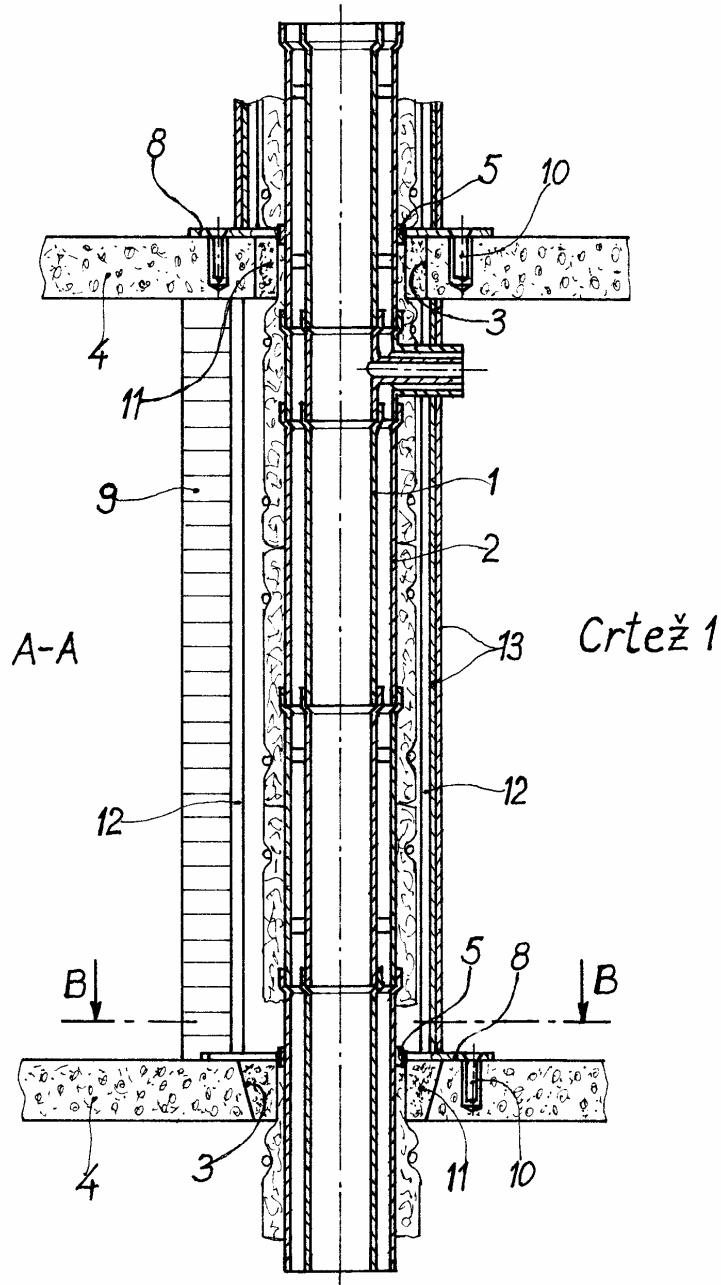

2/2

Crtež 2

B-B

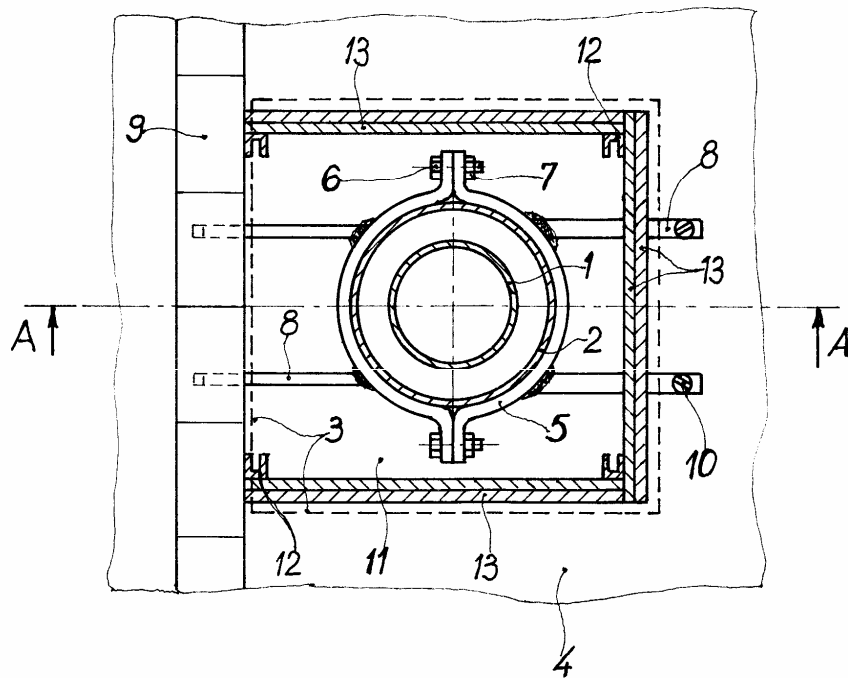

The building of the chimney, i.e. the canal is done by piling their sections from the foundations or the slab between the floors to the final cap above the roof of the building. The body of the chimney, i.e. the canal can be fastened vertically using the two-part ring-like clamps 5 for each slab between the floors, or for every second slab 4, depending on the mass of the body of the chimney or canal.



Picture 3: Support

After the setting up of the chimney i.e. the canal and its connecting to the slabs 4 using the clamps 5, the body of the chimney, i.e. the canal is, throughout its length, shielded with warm insulating material made of mineral wool panels, so that the panels are wrapped around the body of the chimney, i.e. the canal and fastened with wire hoops.

After completing the thermal sheathing, the inter space between the thermal sheathing of the chimney, i.e. the canal and the edges of the openings 3 in the slabs between the floors 4 is filled with a concrete mixture. Before the pouring of the concrete mixture in the inter space, the lower side of the openings 3 are closed with weatherboards on which concrete corks 11 are formed which, through thermal sheathing, tighten around the body of the chimney, i.e. the canal. The concrete corks 11 poured around the body of the chimney, i.e. the canal shielded with mineral wool and the ring-like support 5, that remain permanently connected

with slabs between the floors 4 adopt all mechanical and thermal exertion that will happen on the body of the chimney, i.e. the canal during its usage.



Picture 3: Concrete cork, mineral wool insulator, metal support of the sheathing and the sheathing made of drywall panel

In some rooms the body of the chimney, i.e. the canal with the thermal sheathing which is connected, as described, with the slabs between the floors 4 from which the weatherboards used for the making of the concrete corks 11 are removed, is closed with an outer paneling which is put up on free, visible surfaces of the chimney, i.e. the canal. The outer paneling of the chimney, i.e. the canal is most often made of flat panels shaped like the surface of the multisided prism with the base shaped like a closed or open regular or irregular polygon, most often regular quadrangle or square. In the inner squares of these polygons vertical metal supports 12 are put, the edges of which are fastened to the floor and ceiling slab of the room. The supports 12, when cut, can have the shape of rectangular tube, U profile or L profile. The visible sides of the prism that make the outer paneling are throughout their length covered with one or more layers of drywall panels 13 that are attached to the support 12 with bolts.

Chimneys and canals in the buildings must comply with the functional, fire-prevention and aesthetic conditions valid for residential rooms, being their integral part. During the final construction works in the rooms in which the metal chimney, i.e. the metal canal was made in the described way, the outer surfaces of drywall panels 13 are treated with the same actions and materials used for final works on the walls of the rooms in which the chimneys, i.e. the canals were done.



ROOF

When we bring out metal ventilation shaft next to the chimneys they end up inside the protection grate, under a concrete cap of the already enclosed chimney. Flue tube and air outlet tube are brought out above the concrete cap and we set up an element with a rain cap – air outlet (picture 4). We do it so that the dirty – greasy air from the ventilating canal does not come into the air outlet canal of the chimney.

Picture 4: Air outlet

When there are not any ventilating canals next to the chimney, the air outlet tube of the chimney is put inside the protection grate and under the concrete cap of the enclosed chimney (Picture 5).

Outside the concrete cap only the flue tube is put, on which we put the rain cap.

On the initial part of the chimney (chamber) and on its end (on the roof), you must make access door openings – little doors for controlling and cleaning.

Because of the condensate apparition, it is necessary to take it to a place defined in the project.



Picture 5.

For any further questions and suggestions, do not hesitate to contact us.

The way of installation and composition of materials (valid for all kinds of tin chimneys and ventilation) shown in the following text, are protected by Patent. Any unauthorized, partial or complete application (installation in the way shown here) will be considered intellectual property theft, and will be, as such, legally sanctioned.

INTER BONOS[®] Ltd.

Production, construction services and trade, Registration number: 1850741
Sv.Helene 3, 10430 Samobor, Tel: (1) 3361 729, 3370 643, Fax: 3370 644,
Mobile phone: 091 722 8262, E-mail: info@interbonos.hr
www.interbonos.hr